

VITI TRUCIOLARI TESTA TESTA MEZZA TONDA FINTA RONDELLA COMBI POZI

COMBI POZI TRUSS WASHER HEAD CHIPBOARD SCREWS

ART. 118CB

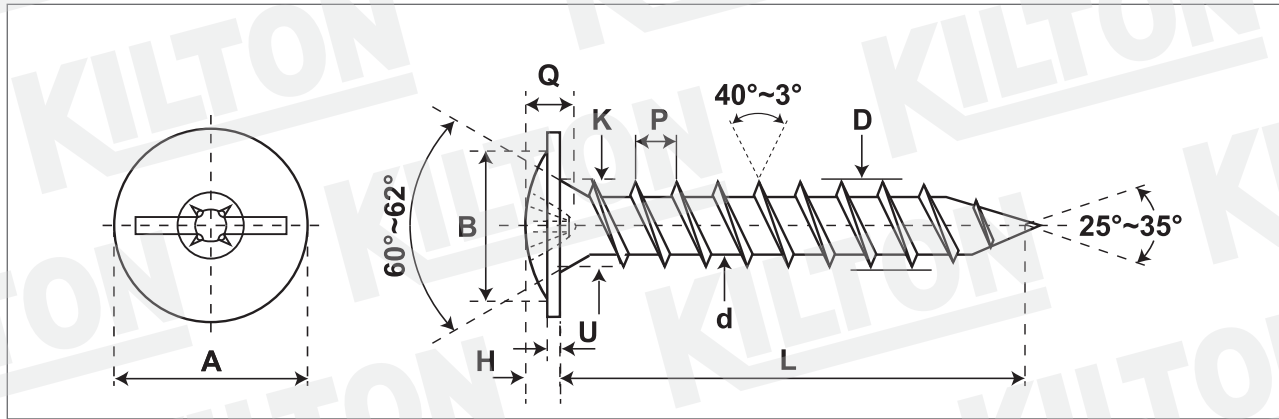

Quantità - Quantity

Materiale - Material

Lunghezza Ribattino - Shank length

Lunghezza Vite - Screw length

Durezza superficie - Surface hardness

Durezza a cuore - Core hardness

Testa Rif. - Head according to Uni/Din

Filetto Rif. - Thread according to Uni/Din

Trattamento superficie - Surface treatment

C1018 - C1022

Hv Min. 550

Hv 300 - 500

Din 7505 B

Din 7505

Zincate Cr3

SIZE	A		B	U	H	Q		Drive n°	K		D		d	P	Case Dept mm.	Torsion min. Kg./cm.	
	min	max				min	max		min	max	min	max					min
M3,5	8,40	8,80	7,20	0,50	2,00	1,47	1,93	2	5,00	5,30	3,35	3,55	2,05	2,30	1,80	0,08-0,18	16
M4	9,60	10,00	8,20	0,80	2,70	1,72	2,16	2	5,50	5,80	3,80	4,10	2,35	2,65	2,00	0,08-0,18	16

Lunghezza nominale/Nominal length: L: da/ from 1 mm a/ to 10 mm incl.+0-0,75 da/ from 11 mm a/ to 30 mm incl.+0-0,90 da/ from 31 mm a/ to 50 mm incl.+0-1,10 da/ from 51 mm a/ to 80 mm incl.+0-1,50 da/ from 81 mm a/ to 120 mm incl.+0-1,75 da/ from 121 mm a/ to 200 mm incl.+0-2.00

Disegno/Drawing:

KLT-A3-0097/1 ART. 118CB

Cod. cliente/Client code:

Confezione/Packing:

Box

Note:

KILTON
PRODUZIONE VITERIE