

VITI TRUCIOLARI TESTA SVASATA PIANA IMPRONTA CROCE POZI

ART. 191.063

POZI FLAT HEAD CHIPBOARD SCREWS

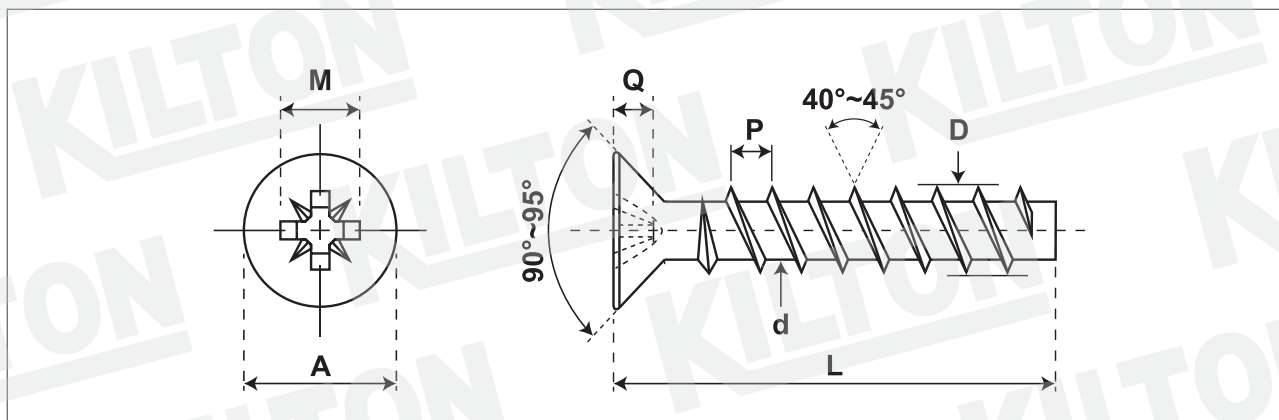

Quantità - Quantity

Materiale - Material

Lunghezza Ribattino - Shank length

Lunghezza Vite - Screw length

Durezza superficiale - Surface hardness

Durezza a cuore - Core hardness

Testa Rif. - Head according to Uni/Din

Filetto Rif. - Thread according to Uni/Din

Trattamento superficiale - Surface treatment

C1018 - C1022

Hv Min. 450

Hv 270 ÷ 390

Din 7505 A

Din 7505

Zincate Cr3

SIZE	A		Q		Drive n°	M	D		d		P	Case Depth mm.	Torsion min. Kg./cm.
	min	max	min	max			min	max	min	max			
6,3	6,70	7,10	2,26	2,71	2	4,70	6,20	6,45	4,10	4,40	1,80	0,12-0,23	44

LT: fino a/up to 60mm = completo/fully 70mm = 42mm +/-1,0mm 80mm = 48mm +/-1,0mm 90mm = 54mm +/-1,0mm 100mm = 60mm +/-1,0mm oltre/over 100mm = 72mm +/-2,0mm

Lunghezza nominale/Nominal length: L: da/from 1 mm a/ to 10 mm incl.+0-0,75 da/from 11 mm a/ to 30 mm incl.+0-0,90 da/from 31 mm a/ to 50 mm incl.+0-1,10 da/from 51 mm a/ to 80 mm incl.+0-1,50 da/from 81 mm a/ to 120 mm incl.+0-1,75 da/from 121 mm a/ to 200 mm incl.+0-2,00

Disegno/Drawing:

KLT-A1-0184/1 ART.191.063

Cod. cliente/Client code:

Confezione/Packing:

Box

Note:

KILTON
PRODUZIONE VITERIE