

# VITI TRILOBATE TESTA SVASATA TORX

## TRILOBULAR TORX FLAT HEAD THREAD FORMING SCREWS

# ART. 441TX

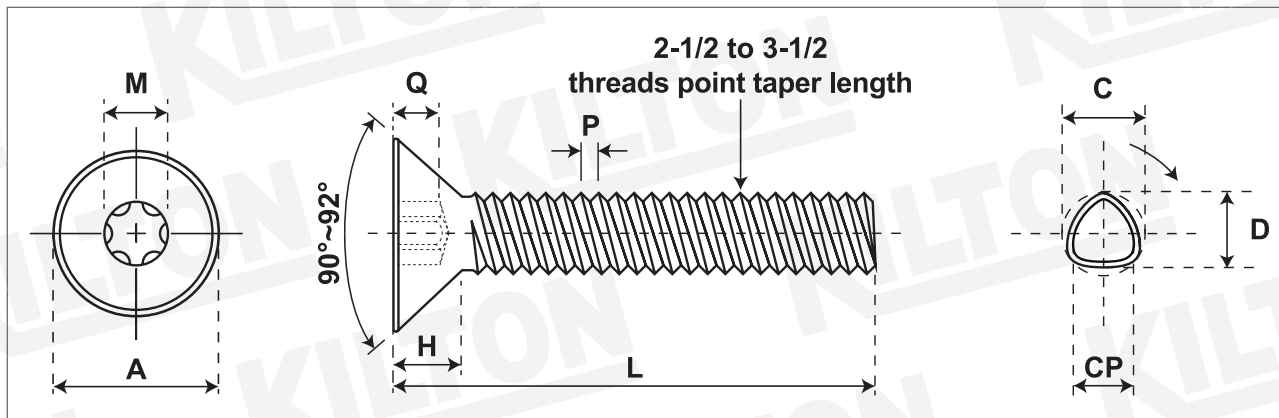

Quantità - Quantity

Materiale - Material

Lunghezza Ribattino - Shank length

Lunghezza Vite - Screw length

Durezza superficiale - Surface hardness

Durezza a cuore - Core hardness

Testa Rif. - Head according to Uni/Din

Filetto Rif. - Thread according to Uni/Din

Trattamento superficie - Surface treatment

1018 - 1022

Hv Min. 450

Hv 270 - 390

Din 13 6g

SIZE	A		H	Q		Torx n°	M	CP max	C		D		P	Case Dept mm.	Torsion min. Kg./cm.
	min	max	max	min	max				min	max	min	max			
M 2,5	4,40	4,70	1,50	1,03	1,15	8	2,38	2,13	2,48	2,56	2,38	2,48	0,45	0,04-0,12	10
M 3	5,30	5,60	1,65	1,03	1,15	10	2,82	2,58	2,98	3,06	2,87	2,97	0,50	0,05-0,18	15
M 3,5	6,14	6,50	1,93	1,14	1,26	15	3,35	2,99	3,48	3,56	3,35	3,46	0,60	0,05-0,18	23
M 4	7,14	7,50	2,20	1,27	1,39	20	3,94	3,40	3,98	4,06	3,84	3,94	0,70	0,10-0,25	34
M 5	8,84	9,20	2,50	1,52	1,64	25	4,53	4,31	5,00	5,09	4,82	4,94	0,80	0,10-0,25	72
M 6	10,57	11,00	3,00	1,65	1,77	30	5,63	5,12	6,00	6,10	5,79	5,94	1,00	0,15-0,28	122
M 8	14,07	14,50	4,00	2,16	2,28	40	6,76	6,91	8,00	8,13	7,76	7,94	1,25	0,15-0,28	295
M 10	17,57	18,00	5,00	3,05	3,17	50	9,02	8,69	10,00	10,15	9,73	9,94	1,50	0,15-0,32	601

**Lunghezza nominale/Nominal length:** L: da/ from 4 mm a/ to 7 mm +/- 0,25 da/ from 8 mm a/ to 11 mm +/- 0,30 da/ from 12 mm a/ to 19 mm +/- 0,30 da/ from 20 mm a/ to 34 mm +/- 0,40 da/ from 35 mm a/ to 54 mm +/- 0,50 oltre/ over 55 incl. mm +/- 1,00

Disegno/Drawing: KLT-A1-0107/1 ART.441TX

Cod. cliente/Client code:

Confezione/Packing: Box

Note:

**KILTON**  
PRODUZIONE VITERIE