

# VITI TRUCIOLARI TESTA SVASATA PIANA IMPRONTA CROCE POZI

## POZI FLAT HEAD CHIPBOARD SCREWS

**ART. 196.45**  
**4,5X11**

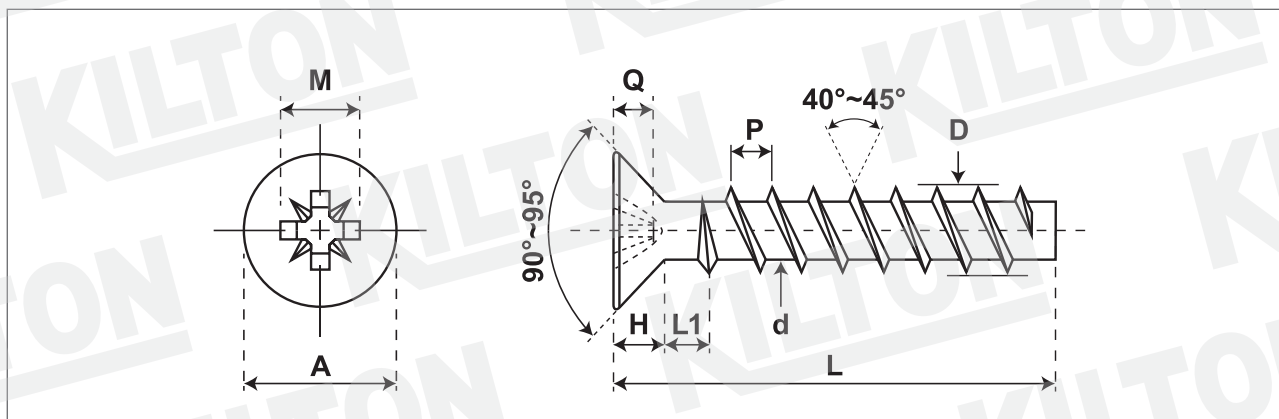

**Quantità - Quantity**

**Materiale - Material**

**Lunghezza Ribattino - Shank length**

**Lunghezza Vite - Screw length**

**Durezza superficiale - Surface hardness**

**Durezza a cuore - Core hardness**

**Testa Rif. - Head according to Uni/Din**

**Filetto Rif. - Thread according to Uni/Din**

**Trattamento superficiale - Surface treatment**

C1018 - C1022

10,2 ÷ 10,3

10,5 ÷ 11,0

Hv Min. 450

Hv 270 ÷ 390

Din 7505 A

Din 7505

Zincate Cr3

SIZE	A		H	Q		Drive n°	M	L1 max	D		d		P	Case Dept mm.	Torsion min. Kg./cm.
	min	max		min	max				min	max	min	max			
4,5	6,90	7,10	2,55	1,60	2,16	2	4,00	1,00	4,25	4,50	2,32	2,70	2,00	0,12-0,23	44

LT: fino a/up to 60mm = completo/fully 70mm = 42mm +/-1,0mm 80mm = 48mm +/-1,0mm 90mm = 54mm +/-1,0mm 100mm = 60mm +/-1,0mm oltre/over 100mm = 72mm +/-2,0mm

**Lunghezza nominale/Nominal length:** L: da/from 1 mm a/ to 10 mm incl.+0-0,75 da/from 11 mm a/ to 30 mm incl.+0-0,90 da/from 31 mm a/ to 50 mm incl.+0-1,10 da/from 51 mm a/ to 80 mm incl.+0-1,50 da/from 81 mm a/ to 120 mm incl.+0-1,75 da/from 121 mm a/ to 200 mm incl.+0-2.00

**Disegno/Drawing:** KLT-A1-0184/1 ART.196.45

**Cod. cliente/Client code:**

**Confezione/Packing:** Box

**Note:**

**KILTON**  
PRODUZIONE VITERIE