

# VITI PER PLASTICA HI-LO TESTA MEZZA TONDA CROCE TORX

## TORX TRUSS WASHER HEAD PLASTIC SCREWS HI-LO THREAD

# ART. 164TX.05

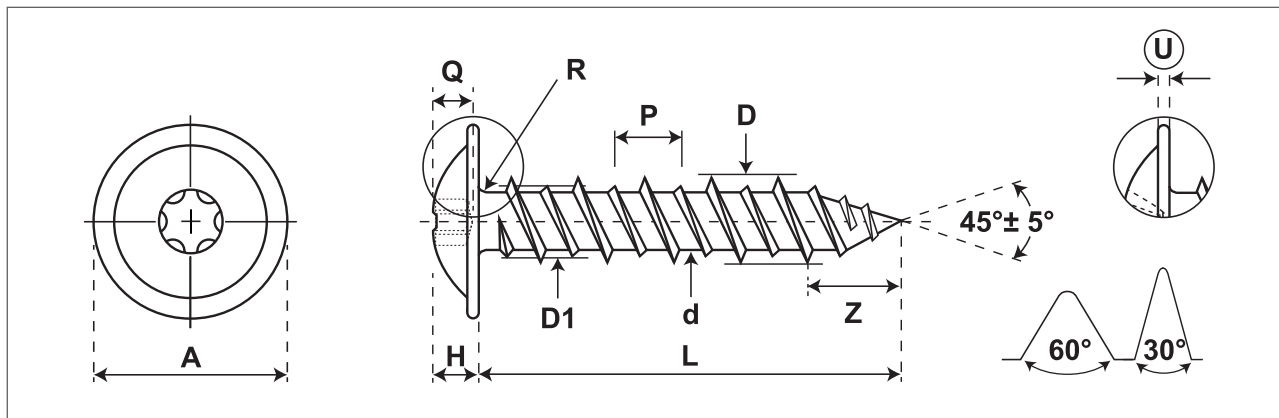

Quantità - Quantity

Materiale - Material **DA 344**

C1018 - C1022

Lunghezza Ribattino - Shank length

Lunghezza Vite - Screw length

Durezza superficie - Surface hardness

Classe 10.9

Durezza Rockwell - Core Rockwell

Hr 32 - 39

Testa Rif. - Head according to Uni/Din

Uni 9708

Filetto Rif. - Thread according to Uni/Din

Uni 9702

Trattamento superficie - Surface treatment

Crezze

SIZE	A		H		Q		Drive n°	R	U		D1	D		d	P	Z max	Torsion min. Kg./cm.
	min	max	min	max	min	max			min	max		min	max				
5	9,39	9,75	2,71	2,95	1,80	2,46	T20	0,60	0,88	1,12	3,79	4,80	5,10	3,00	3,00	3,70	64

**Lunghezza nominale/Nominal length:** L: da/ from 3,5 mm a/ to 6 mm +/- 0,60 da/ from 7 mm a/ to 10 mm +/- 0,75 da/ from 10 mm a/ to 18 mm +/- 0,90 da/ from 18 mm a/ to 30 mm +/- 1,05 da/ from 30 mm a/ to 50 mm +/- 1,25 da/ from 50 mm a/ to 80 mm +/- 1,50 da/ from 90 mm a/ to 100 mm +/- 1,75

Disegno/Drawing: KLT-B1-1155/2 ART.164TX.05

Cod. cliente/Client code:

Confezione/Packing:

Note:

**KILTON**  
PRODUZIONE VITERIE