

VITE AUTOFORANTE TESTA MEZZA TONDA FINTA RONDELLA TORX TORX TRUSS WASHER HEAD SELF DRILLING SCREWS

ART. 044TX

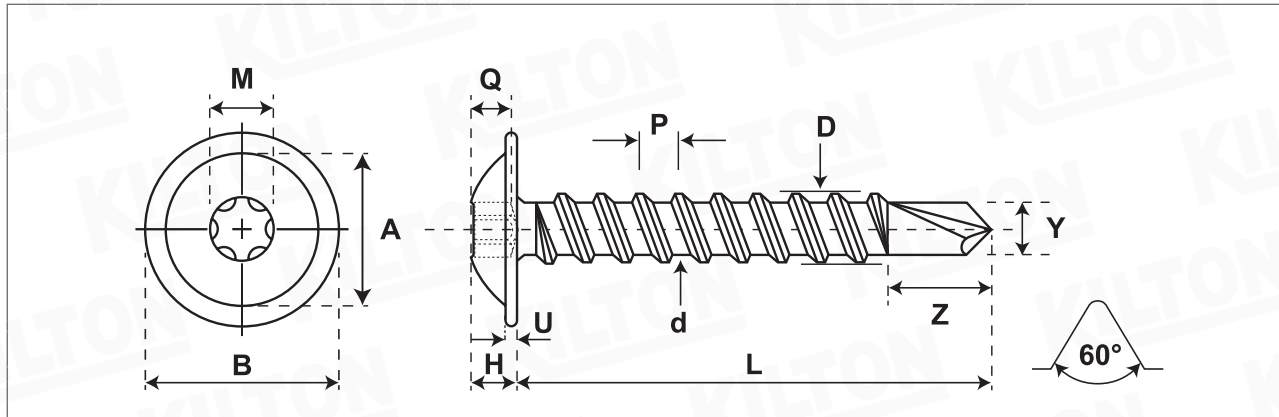

Quantità - Quantity

Materiale - Material

1018 - 1022

Lunghezza Ribattino - Shank length

Lunghezza Vite - Screw length

Durezza superficie - Surface hardness

Hv.03 Min. 560

Durezza a cuore - Core hardness

Hv.03 270 - 425

Testa Rif. - Head according to Uni/Din

Filetto Rif. - Thread according to Uni/Din

Din 7504

Trattamento superficie - Surface treatment

Zincate Cr3

SIZE	A		B		H		Q		Drive n°	U	D		d	P	Z ref. n° 3	Y max	Case Depht mm.	Torsion min. Kg./cm.
	min	max	min	max	min	max	min	max			min	max						
3,5	7,70	8,15	8,50	9,00	1,88	2,18	1,14	1,40	T-15	0,90	3,35	3,53	2,57	1,30	4,75	2,80	0,05-0,18	29
3,9	8,46	8,94	9,50	10,00	2,06	2,39	1,14	1,40	T-15	0,90	3,73	3,91	2,84	1,40	4,75	3,10	0,10-0,23	35
4,2	9,24	9,75	10,00	10,50	2,24	2,60	1,42	1,80	T-20	1,15	4,04	4,22	3,02	1,40	5,75	3,60	0,10-0,23	46
4,8	10,80	11,38	11,80	12,50	2,62	3,00	1,64	2,03	T-25	1,15	4,62	4,80	3,50	1,60	6,75	4,10	0,10-0,23	66
5,5	12,37	13,00	13,50	14,20	3,00	3,40	1,65	2,03	T-25	1,35	5,26	5,46	4,08	1,80	7,75	4,80	0,10-0,23	102
6,3	13,46	14,15	14,50	15,20	3,28	3,71	2,02	2,42	T-30	1,35	6,03	6,25	4,79	1,80	8,75	5,80	0,15-0,28	143

Lunghezza nominale/Nominal length: L: fino a/up to 15 mm incl. +/- 0,75 da/from 16 mm a/to 18 mm +/- 0,90 da/from 19 mm a/to 25 mm +/- 1,00 da/from 26 mm a/to 50 mm +/- 1,25 oltre/over 50 mm +/- 1,50

Disegno/Drawing: KLT-A1-085/1 ART.044TX

Cod. cliente/Client code:

Confezione/Packing: Box

Note:

KILTON
PRODUZIONE VITERIE