

# VITI TRUCIOL. TESTA SVASATA PIANA IMPR. CROCE POZI CON FRESE 1/2 FILETTO

## POZI FLAT HEAD WITH 6 NIBS CHIPBOARD SCREWS PARTIAL THREAD

# ART. 144

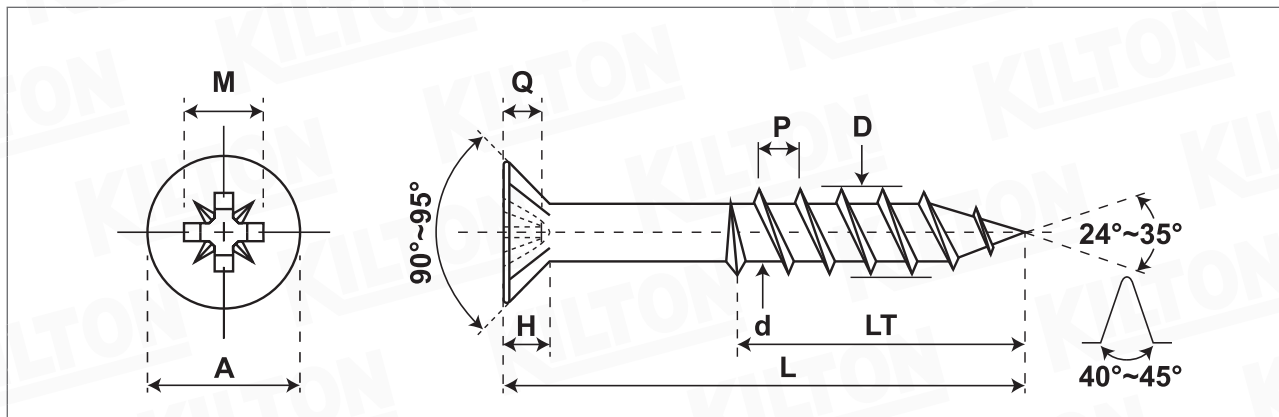

Quantità - Quantity

Materiale - Material

Lunghezza Ribattino - Shank length

Lunghezza Vite - Screw length

Durezza superficiele - Surface hardness

Durezza a cuore - Core hardness

Testa Rif. - Head according to Uni/Din

Filetto Rif. - Thread according to Uni/Din

Trattamento superficiele - Surface treatment

C1018 - C1022

Hv Min. 550

Hv 300 - 500

Din 7505 A

Din 7505

Zincate Cr3

SIZE	A		H	Q		Drive n°	M	R max	L1 max	D		d		P	Case Depth mm.	Torsion min. Kg./cm.
	min	max		min	max					min	max	min	max			
3,5	6,64	7,00	3,60	1,76	2,16	2	4,00	1,80	2,60	3,25	3,50	2,00	2,25	1,60	0,08-0,18	20
4	7,64	8,00	4,25	2,05	2,51	2	4,40	2,00	2,80	3,75	4,00	2,30	2,50	1,80	0,12-0,23	31
4,5	8,64	9,00	4,60	2,46	3,02	2	4,80	2,20	3,00	4,25	4,50	2,50	2,70	2,00	0,12-0,23	44
5	9,64	10,00	5,20	2,99	3,55	2	5,30	2,50	3,20	4,75	5,10	2,90	3,10	2,20	0,12-0,23	64
6	11,57	12,00	6,00	3,20	3,65	3	6,60	2,50	3,60	5,75	6,15	3,60	3,80	2,60	0,15-0,28	100

LT: 30mm = 18mm +/-1,0mm 35mm = 21mm +/-1,0mm 40mm = 25mm +/-1,0mm 45mm = 28mm +/-1,0mm 40mm = 25mm +/-1,0mm 45mm = 28mm +/-1,0mm

50mm = 30mm +/-1,0mm 60mm = 35mm +/-1,0mm 70mm = 45mm +/-1,0mm 80mm = 48mm +/-1,0mm

**Lunghezza nominale/Nominal length:** L: da/from 1 mm a/to 10 mm incl.+0-0,75 da/from 11 mm a/to 30 mm incl.+0-0,90 da/from 31 mm a/to 50 mm incl.+0-1,10 da/from 51 mm a/to 80 mm incl.+0-1,50 da/from 81 mm a/to 120 mm incl.+0-1,75 da/from 121 mm a/to 200 mm incl.+0-2.00

Disegno/Drawing: KLT-A1-088/1 ART.144

Cod. cliente/Client code:

Confezione/Packing: Box

Note:

**KILTON**  
PRODUZIONE VITERIE