

# VITI TRUCIOLARI TESTA SVASATA PIANA IMPRONTA CROCE POZI

## POZI FLAT HEAD CHIPBOARD SCREWS

# ART. 112

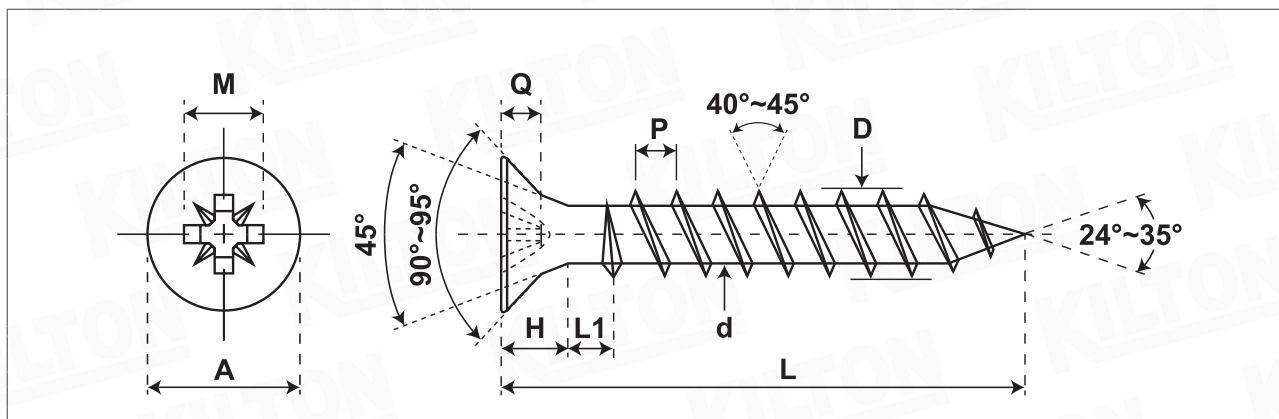

Quantità - Quantity

Materiale - Material

Lunghezza Ribattino - Shank length

Lunghezza Vite - Screw length

Durezza superficie - Surface hardness

Durezza a cuore - Core hardness

Testa Rif. - Head according to Uni/Din

Filetto Rif. - Thread according to Uni/Din

Trattamento superficie - Surface treatment

C1018 - C1022

Hv Min. 550

Hv 300 - 500

Din 7505 A

Din 7505

Zincate Cr3

SIZE	A		H	Q		Drive n°	M	L1 max	D		d		P				Case Depht mm.	Torsion min. Kg./cm.
	min	max		min	max				min	max	min	max						
2,5	4,70	5,05	2,50	1,22	1,57	1	2,51	2,10	2,30	2,50	1,40	1,60	1,10				0,05-0,10	11
3	5,70	6,05	3,20	1,60	2,11	1	3,00	2,35	2,80	3,00	1,75	1,90	1,35				0,08-0,18	16
3,5	6,64	7,05	3,60	1,76	2,16	2	4,00	2,60	3,25	3,50	2,00	2,25	1,60				0,08-0,18	22
4	7,64	8,05	4,25	2,05	2,51	2	4,40	2,80	3,75	4,00	2,30	2,50	1,80				0,12-0,23	33
4,5	8,64	9,05	4,60	2,46	3,02	2	4,80	3,00	4,25	4,50	2,50	2,70	2,00				0,12-0,23	45
5	9,64	10,05	5,20	2,99	3,55	2	5,30	3,20	4,75	5,00	2,90	3,10	2,20				0,12-0,23	64
6	11,57	12,05	6,00	3,20	3,65	3	6,60	3,60	5,75	6,00	3,60	3,80	2,60				0,15-0,28	100

**Lunghezza nominale/Nominal length:** L: da/ from 1 mm a/ to 10 mm incl.+0-0,75 da/ from 11 mm a/ to 30 mm incl.+0-0,90 da/ from 31 mm a/ to 50 mm incl.+0-1,10 da/ from 51 mm a/ to 80 mm incl.+0-1,50 da/ from 81 mm a/ to 120 mm incl.+0-1,75 da/ from 121 mm a/ to 200 mm incl.+0-2.00

Disegno/Drawing: KLT-A3-0013/8 ART.112

Cod. cliente/Client code:

Confezione/Packing: Box

Note:

**KILTON**  
PRODUZIONE VITERIE